

PRORIL

50 Hz

Designed for continuous operations, excellent performance and easy maintenance, PRORIL Tank series pumps have proven their reliability and durability in demanding areas like construction, mining, tunneling, quarries, industries and rental applications.

Dewatering Pump

TANK 222

High Chrome Dewatering Pump



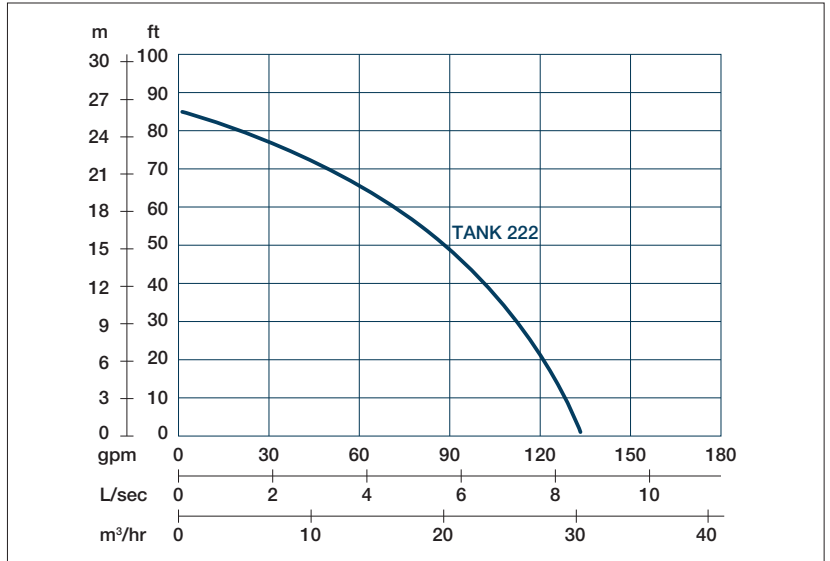

Shaft Speed : 2850rpm

Solid Passage: 9mm

Outlet : 50mm, 2in

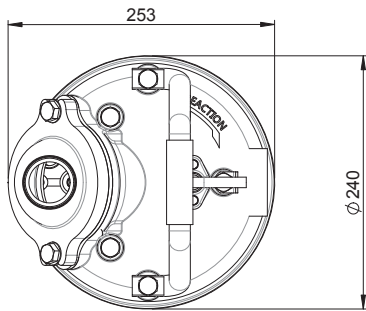

OUTPUT	HEAD	FLOW
2.2 kW	Rated : 15m, 49ft	Rated : 5 l/s, 79gpm
3 HP	Max : 26m, 85ft	Max : 8.3 l/s, 132gpm

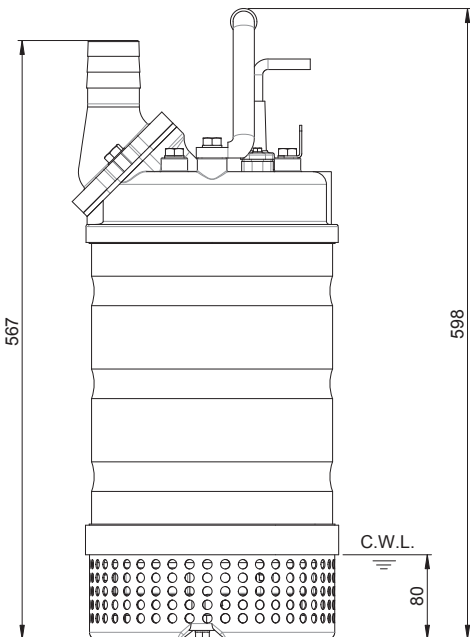

Weight : 35kg / 77 lbs

Pump Type		Electric Submersible Pumps
		3-Phase
Motor	Type	Induction Motor
	Poles	2 Pole
	Insulation	Class F
	Protector	Circle Thermal Protector
	Starter	D.O.L.
Lubricant		Food Grade (ISO VG32)
Impeller Type		Opened
Shaft Seal		Double Mechanical Seal Silicon Carbide VS Ceramic / Carbon
Bearings		C3 Shielded ball bearings
Cable		H07BQF Length: 20m (66ft) or longer upon request.
Materials	Pump Casing	Gray Iron
	Impeller	Chromium Iron
	Motor Frame	Stainless Steel
	Motor Shaft	Stainless Steel
	Strainer	Stainless Steel
Max. Liquid Temperature		104°F (40°C)
Max. Submersion Depth		66ft (20m)
pH Range		pH 5 - pH 8